



Cetetherm Pioneer

Heating and domestic hotwater substation for apartments and single family houses

The Cetetherm Pioneer Heat Interface Unit is installation ready for complete central heating and hot water requirements. Pioneer can be connected online for remote control and monitoring.

It is suitable for apartments and single-family houses that are indirectly connected to a local heating or district heating network.

Cetetherm has many years of experience in district heating technology, which is put to expert use in Pioneer, with well-thought functionality and focus on easy handling.

BENEFITS

- Connected for remote control and monitoring.
- App for smartphones, where you can control your facility.
- Low return temperature with stable and fast hot water regulation.
- Compact with neat design.
- Valves and pump send their status and current operating data is visible via the room panel.
- Comfortable tapwater control with built in energy optimised idle function.
- Metering connections for individual measuring of energy usage, cold and hot water flow.
- Room panel for space heating that is easy to start up and easy to use.

HIGH COMFORT

The Pioneer has a fully automatic individual temperature setting for central heating and hot water. Heat is automatically regulated, depending on outdoor temperature and/or the temperature desired inside the dwelling.

Domestic hot water is heated separately in a high-capacity heat exchanger, ensuring that the hot water is always as fresh as the incoming cold water mains supply.

SIMPLE INSTALLATION

Compact dimensions with well arranged plumbing and factory-complete internal wiring – all make installation very simple. A pre-programmed control unit and a power cable already fitted with a plug make things even simpler to allow immediate start-up.

Pioneer is mounted on an insulated frame and includes an insulated cover. Better insulation means less energy usage and higher energy efficiency. In addition, the pipes can be connected up or down depending on the layout of the building.

FUTURE-PROOFED

Pioneer's powerful and unique software is future-proofed throughout Pioneer's lifetime and can be updated remotely or locally as new features and accessories become available.

Pioneer represents the most modern technology, and provides the answer to stringent demands for long term

performance. All components are closely matched and carefully tested to function in accordance with 3rd party certified quality assurance system ISO 9001. Pioneer is CE approved and Swedish P-labeled.

HEATING NETWORK – A GOOD SOURCE OF HEAT

A community or district heating network is an efficient technology that meets the need for central heating and hot water in a simple, convenient, and secure way. The expansion of district heating to its current level has reduced emission of greenhouse gases from heating by about 20%. The economics of district heating are very competitive compared with other forms of heating.

Pioneer has been designed to meet the future with low temperature district heating.

OPERATION

The Pioneer is used to transfer heat from the primary network to the water in the dwelling's central heating and hot water system.

Heat is transferred through a heat exchanger of acid-resistant, stainless-steel plates, which keep the primary network completely separated from the dwelling's own system.

The control panel with the indoor sensor is always included and increase the comfort and saves energy.

When no heating flow is required, the heating circulation pump stops automatically, but it will run occasionally. The pump has a built in energy saving function.

When no tap water is used the built-in idle function takes over and keeps the unit ready for production of tap water as well as keeping the return temperature and flow to a minimum.

The use of energy is registered with an external energy meter. Measurement is done by recording the flow of primary network through the system, and by measuring the temperature difference between the medium's supply and return flow.

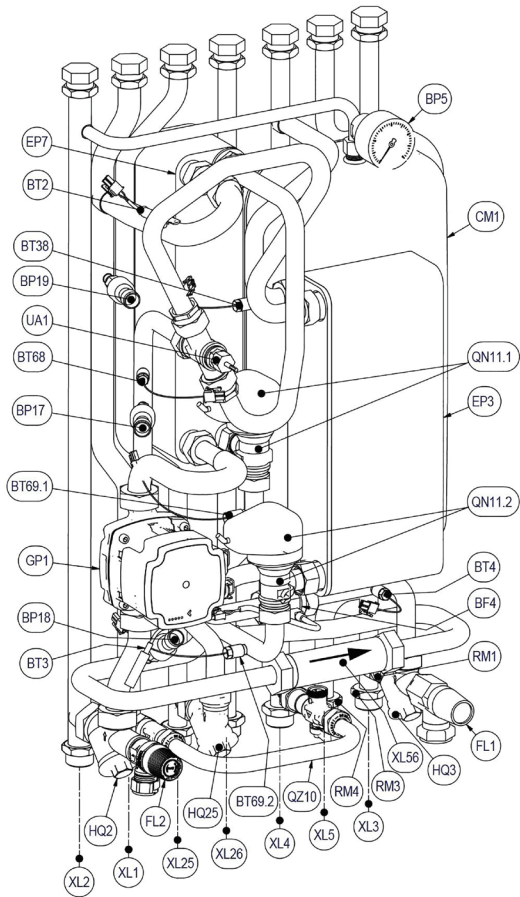

DIAGRAMMATIC FLOW CHART FOR PIONEER

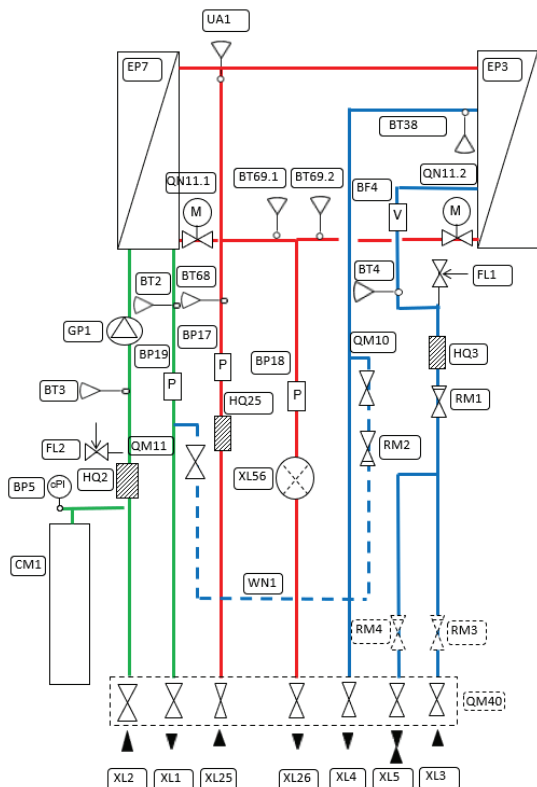

COMPONENTS

Connections

- XL1 Heating system, supply
- XL2 Heating system, return
- XL3 CW
- XL4 DHW
- XL5 DHWC
- XL25 Primary network, supply
- XL26 Primary network, return
- XL56 Heat meter connection

Sensors

- BF4 DHW flow sensor
- BP5 Pressure gauge, heating system
- BP17 Pressure sensor, Primary network supply
- BP18 Pressure sensor, Primary network return
- BP19 Pressure sensor, heating system
- BT1 Outdoor sensor
- BT2 Temperature sensor, heating system flow
- BT3 Temperature sensor, heating system return
- BT4 CW temperature sensor
- BT38 DHW temperature sensor
- BT50 Room sensor
- BT68 Temperature sensor, Primary network supply
- BT69.1 Temperature sensor, Primary network return, RAD
- BT69.2 Temperature sensor, Primary network return, DHW
- UA1 Heat meter sensor connection

Electronic components

- AA2 Circuit board, main controller, ASB
- AA4 Room control unit RMU, including room sensor
- AA31 Communication module, CMO40*

VVS- components

- CM1 Expansion vessel
- EP3 Heat exchanger, hot water
- EP7 Heat exchanger, heating
- FL1 Safety valve DHW
- FL2 Safety valve, heating system
- GP1 Circulator pump, heating system
- HQ2 Filter heating circuit
- HQ3 Filter, CW
- HQ25 Filter, Primary network supply
- QM40 First fix jig with shut-off valves*
- QN11.1 Control valve and actuator, heating circuit
- QN11.2 Control valve and actuator, tap water circuit
- RM1 Check valve for CW
- RM3 Check valve for CW, * enclosed when DHWC
- RM4 Check valve for DHWC, * enclosed when DHWC
- QZ10 Filling loop, containing:
 - WN1 Filling hose
 - QM10 Filling valve, HW
 - QM11 Filling valve, heating system
 - RM2 Check valve, filling

* option

OPERATING DATA

	Heating medium	Heating circuit	Hot water circuit
Design pressure, Bar	16	10	10
Design temperature, °C	120	90	90
Opening pressure, safety valve, Bar	-	2,5	9

PERFORMANCE AT DIFFERENTIAL PRESSURE MIN 50 KPA AND MAX 600* KPA

Model	Designed temperature programme (°C)	Capacity (kW)	Primary flow (l/s)	Secondary flow (l/s)
Hot water circuit				
Pi1 2250	65-22/10-50	50	0,28	0,30
Pi1 2255	65-22/10-50	55	0,31	0,33
Heating circuit				
	100-63/60-80	14	0,09	0,17
	100-43/40-60	22	0,09	0,26
	100-30/30-35	5,3	0,018	0,25

* Depending on option

CONNECTIONS

Connections	Pioneer	First fix-jig
	External thread	External thread
Primary network supply	G 3/4"	G 1"
Primary network return	G 3/4"	G 1"
Heating system supply	G 3/4"	G 1"
Heating system return	G 3/4"	G 1"
Cold water inlet	G 3/4"	G 1"
Cold water outlet	G 3/4"	G 1"
Hot water	G 3/4"	G 1"

OTHER INFORMATION

Electrical data: 230 V, 1-phase, 50 W
Dimensions (cover): 445 mm width × 256 mm depth, 789 mm height
Dimensions (without cover) 432 mm width × 247 mm depth, 789 mm height
Weight: 30 kg
Transport particulars: Total weight 34 kg, 0,2 m ³
Noise: <55 dB
Differential pressure min 50 kPa and max 600 kPa

AN EASILY MANAGEABLE, ECONOMICAL AND DURABLE SOURCE OF HEAT

Pioneer is a wall-mounted unit and is very compact, quiet with neat design. To minimize transmission of operational sounds, we recommend installing it on well insulated walls or on walls of concrete.

Pioneer requires no attendance or maintenance and has a very long operational life.

To save time and efficiency the installation, Cetetherm offers a first-fix-jig including shut-off valves.

OPTION

First fix jig with shut-off valves.

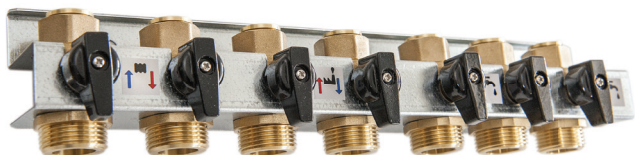

Communication module to connect Pioneer to the Cetetherm myUplink app.



CETETHERM MYUPLINK

The Cetetherm myUplink app provides a quick overview of the Pioneer status and of the heating in your home.

This solution makes it easy to follow and control the heat production. A push notification is sent if the Pioneer is affected by operational disturbances.

MyUplink is a fast and efficient tool to easily control your Pioneer, regardless of where you are.

MyUplink is distinct and easy-to-use, for monitoring and control. It also logs the HIU's parameters in a user-friendly history chart.